

BRE Global Client Report

Extended application report in accordance with EN 15882-3:2009 on Sure Snap fire collars

Prepared for: Devar International Holdings Pty Ltd

Date: 25 July 2023

Report Number: P104650-1003 Issue 2

BRE Global Ltd
Watford, Herts
WD25 9XX

Customer Services 0333 321 8811

From outside the UK:
T + 44 (0) 1923 664000
F + 44 (0) 1923 664010
E enquiries@bregroup.com
www.bregroup.com

Prepared for:
Devar International Holdings Pty Ltd
3 Skirmish Court
Victoria Point
Queensland
4165
Australia



Prepared by

Name	Andy Russell
Position	Principal Consultant
Date	25 July 2023
Signature	

Authorised by

Name	Tony Baker
Position	Head of Technical Standards and Delivery - Passive
Date	25 July 2023
Signature	

Date of original report	06 June 2019
Date of this reissue	25 July 2023
Date of next review	06 June 2024

This report is made on behalf of BRE Global and may only be distributed in its entirety, without amendment, and with attribution to BRE Global Ltd to the extent permitted by the terms and conditions of the contract. Assessment results relate only to the specimens tested. BRE Global has no responsibility for the design, materials, workmanship or performance of the product or specimens assessed. This report does not constitute an approval, certification or endorsement of the product assessed and no such claims should be made on websites, marketing materials, etc. Any reference to the results contained in this report should be accompanied by a copy of the full report, or a link to a copy of the full report.

BRE Global's liability in respect of this report and reliance thereupon shall be as per the terms and conditions of contract with the client and BRE Global shall have no liability to third parties to the extent permitted in law.



Table of contents

1	Introduction	3
2	Details of the product or building element concerned	3
2.1	Nature	3
2.2	Description	3
2.2.1	Sure Snap cast-in H65S collar	3
2.2.2	Sure Snap cast-in H100S collar	3
2.2.3	Sure Snap cast-in H110S collar	4
2.2.4	Sure Snap cast-in H150S collar	4
2.2.5	Sealing around pipes	4
3	Test reports and test results in support of this extended application report	5
3.1	Test reports	5
3.2	Test results in accordance with EN 1366-3	6
4	Extended application	14
4.1	Principles applied for the extension of the field of application	14
4.2	Procedure	14
4.2.1	Principles common to all generic seal types	14
4.2.2	Principles to specific generic seal types	14
5	Extended application results	15
5.1	Application range – product family	15
5.2	Fire performance parameters	15
5.2.1	PVC pipes	16
5.2.2	PVC pipes with pipe socket within fire collar	16
5.2.3	PP pipes	17
5.2.4	PP pipes with pipe bell end within fire collar	17
5.2.5	PE-HD pipes	18
5.2.6	PE-X pipes	18
6	Figures	19
7	Additional statement	23
8	Validity of the extended application	23



1 Introduction

This extended application report concerns test results obtained in accordance with Test Method EN 1366-3:2009.

The extended application process is carried out in conformity with the following extended application standard: EN 15882-3:2009, *Extended applications of results from fire resistance tests for service installations. Part 3: Penetration seals*.

This report is Issue 2 of BRE Global extended application report no. P104650-1003 and has been reissued to include an additional test, P112838-1008 Issue 1, the measured diameters and wall thicknesses of the pipes and the measured wall thicknesses of the sockets and pipe bell ends. The report was also reformatted in line with EN 15725:2023, *Extended application on the fire performance of construction products and building elements: Principle of EXAP standards and EXAP reports*.

BRE Global report no. P104650-1003 Issue 1, dated 07 May 2019, is withdrawn and replaced with effect from the date of this Issue 2 report.

2 Details of the product or building element concerned

2.1 Nature

Product technical specifications:	Pipe closure device.
Product family:	Sure Snap fire collars.
Intended use:	Penetration seal to maintain the fire resistance of concrete compartment floors at the position at which it is penetrated by a plastic pipe.
End use application:	The sealing of openings in concrete compartment floors for plastic pipes

2.2 Description

2.2.1 Sure Snap cast-in H65S collar

The Sure Snap cast-in H65S collar, details of which are shown in figure 1, comprises a 1.6mm-thick polypropylene casing with an 84mm inner diameter and a 168mm-diameter base flange. The 250mm-high collar casing, which is cut down in length to match the floor thickness, incorporates a 280mm x 65mm x 5mm-thick intumescent sheet and a rubber ring seal. The closing mechanism comprises three 3.15mm-diameter galvanised steel springs bound with nylon fuse links and a 322mm x 63mm x 0.25mm-thick stainless-steel mesh.

2.2.2 Sure Snap cast-in H100S collar

The Sure Snap cast-in H100S collar, details of which are shown in figure 2, comprises a 1.6mm-thick polypropylene casing with a 126.5mm inner diameter and a 213mm-diameter base flange. The 250mm-high collar casing, which is cut down in length to match the floor thickness, incorporates a 412mm x



85mm x 4mm-thick intumescent sheet and a rubber ring seal. The closing mechanism comprises three 3.15mm-diameter galvanised steel springs bound with nylon fuse links and a 460mm x 83mm x 0.25mm-thick stainless-steel mesh.

2.2.3 Sure Snap cast-in H110S collar

The Sure Snap cast-in H110S collar, details of which are shown in figure 3, comprises a 1.9mm-thick polypropylene casing with a 138mm inner diameter and a 194mm x 184mm rectangular base flange. The 248mm-high collar casing, which is cut down in length to match the floor thickness, incorporates a 451mm x 85mm x 4mm-thick intumescent sheet and a rubber ring seal. The closing mechanism comprises four 3.15mm-diameter galvanised steel springs bound with nylon fuse links and a 503mm x 83mm x 0.25mm-thick stainless-steel mesh.

2.2.4 Sure Snap cast-in H150S collar

The Sure Snap cast-in H150S collar, details of which are shown in figure 4, comprises a 2mm-thick polypropylene casing with a 182mm inner diameter and a 292mm-diameter base flange. The 250mm-high collar casing, which is cut down in length to match the floor thickness, incorporates a 600mm x 110mm x 6mm-thick intumescent sheet and a rubber ring seal. The closing mechanism comprises four 4mm-diameter galvanised steel springs bound with nylon fuse links and a 640mm x 109mm x 0.25mm-thick stainless-steel mesh.

2.2.5 Sealing around pipes

Where there is a gap between the aperture in the floor and the pipe circumference, this is filled using one of the following methods:

- a) For gaps up to 10mm wide: No backfill is required.
- b) For gaps between 10mm wide and 20mm wide: Sika Everbuild Everflex LMA 200 Contractors Sealant is required.
- c) For gaps between 20mm wide and 40mm wide: General Purpose Construction Grout is required.

Where Weber Saint Gobain No-shrink General Purpose Construction Grout is used, a cardboard gasket is located between the pipe and the aperture in the floor and the grout applied in the gap above this. The cardboard gasket is positioned either 30mm below the upper surface of the floor or on the rubber ring of the collar if this is less than 30mm below the surface of the floor.

Where Sika Everflex LMA 200 Contractors Sealant is used, this is applied between the pipe and the aperture in the floor to a depth of 10mm.

In addition to the above, a PE foam strip, nominally 5mm thick x 30mm wide, must be applied around polypropylene pipes, flush with the top of the floor.



3 Test reports and test results in support of this extended application report

3.1 Test reports

Name of laboratory	Name of sponsor	Test report ref. no.	Date
BRE Global Limited	Devar International Holdings Pty Ltd	P112838-1000 Issue 1	05 December 2018
BRE Global Limited	Devar International Holdings Pty Ltd	P112838-1001 Issue 1	05 December 2018
BRE Global Limited	Devar International Holdings Pty Ltd	P112838-1002 Issue 1	05 December 2018
BRE Global Limited	Devar International Holdings Pty Ltd	P112838-1003 Issue 3	24 January 2020
BRE Global Limited	Devar International Holdings Pty Ltd	P112838-1004 Issue 1	05 December 2018
BRE Global Limited	Devar International Holdings Pty Ltd	P112838-1005 Issue 2	24 April 2019
BRE Global Limited	Devar International Holdings Pty Ltd	P112838-1006 Issue 1	05 December 2018
BRE Global Limited	Devar International Holdings Pty Ltd	P112838-1007 Issue 1	05 December 2018
BRE Global Limited	Devar International Holdings Pty Ltd	P112838-1008 Issue 1	05 August 2020



3.2 Test results in accordance with EN 1366-3

Test report ref.	Specimen	Collar	Pipe type	Pipe external diameter		Pipe wall thickness		Socket/pipe bell end wall thickness	Socket/pipe bell end within the collar	Seal method	Integrity (min)	Insulation (min)
				Nominal (mm)	Measured (mm)	Nominal (mm)	Measured (mm)	Measured (mm)				
P112838-1000 Issue 1	1	H150S	PVC	150	160	9.5	10.1	9.9	Socket	None	202	148
P112838-1000 Issue 1	2	H110S	PVC	100	110	6.6	7.3	7.0	Socket	None	202	202
P112838-1000 Issue 1	3	H110S	PVC	50	50	3.7	5.0	5.2	Socket	None	202	202
P112838-1000 Issue 1	4	H110S	PE-HD	50	50	3.0	3.4	N/A	None	None	164	164
P112838-1000 Issue 1	5	H150S	PVC	100	110	6.6	7.3	7.0	Socket	None	194	172
P112838-1000 Issue 1	6	H110S	PE-HD	110	110	4.3	5.0	N/A	None	None	202	202
P112838-1001 Issue 1	1	H100S	PVC	100	110	3.2	3.4	3.2	Socket	None	240	233



Test report ref.	Specimen	Collar	Pipe type	Pipe external diameter		Pipe wall thickness		Socket/pipe bell end wall thickness	Socket/pipe bell end within the collar	Seal method	Integrity (min)	Insulation (min)
				Nominal (mm)	Measured (mm)	Nominal (mm)	Measured (mm)	Measured (mm)				
P112838-1001 Issue 1	2	H100S	PVC	50	56	2.0	2.0	2.0	Socket	None	240	226
P112838-1001 Issue 1	3	H100S	PVC	100	110	3.2	3.4	N/A	None	None	240	240
P112838-1001 Issue 1	4	H100S	PVC	50	56	2.0	2.0	N/A	None	None	240	223
P112838-1001 Issue 1	5	H100S	PE-HD	110	110	4.2	4.8	N/A	None	None	240	240
P112838-1001 Issue 1	6	H100S	PE-HD	50	50	3.0	3.6	N/A	None	None	215	215
P112838-1002 Issue 1	1	H65S	PEX-a	63	63	8.6	9.7	N/A	None	None	100	100
P112838-1002 Issue 1	2	H110S	PP	50	50	1.8	2.3	2.3	Pipe bell end	Grout backfill	118 ¹	118 ¹
P112838-1002 Issue 1	3	H110S	PP	110	110	3.4	3.8	3.8	Pipe bell end	None	240	234



Test report ref.	Specimen	Collar	Pipe type	Pipe external diameter		Pipe wall thickness		Socket/pipe bell end wall thickness	Socket/pipe bell end within the collar	Seal method	Integrity (min)	Insulation (min)
				Nominal (mm)	Measured (mm)	Nominal (mm)	Measured (mm)	Measured (mm)				
P112838-1002 Issue 1	4	H110S	PVC	100	110	3.2	3.8	N/A	None	None	202	202
P112838-1002 Issue 1	5	H65S	PP	50	50	1.8	2.7	2.7	Pipe bell end	Silicone	240	231
P112838-1002 Issue 1	6	H110S	PVC	100	110	3.2	3.4	N/A	None	Silicone	239	218
P112838-1003 Issue 3	1	H65S	PP	40	40	1.8	1.8	1.8	Pipe bell end	Silicone	240	227
P112838-1003 Issue 3	2	H65S	PVC	40	40	3.0	3.5	3.5	Socket	Silicone	240	218
P112838-1003 Issue 3	3	H150S	PVC	150	160	2.0	3.3	N/A	None	None	151	151
P112838-1003 Issue 3	4	H110S	PVC	100 manifold	110	3.0	3.5	N/A	None	None	240	227
P112838-1003 Issue 3	5	H65S	PEX-a	15	16	2.6	3.1	N/A	None	Grout backfill	240	223



Test report ref.	Specimen	Collar	Pipe type	Pipe external diameter		Pipe wall thickness		Socket/pipe bell end wall thickness	Socket/pipe bell end within the collar	Seal method	Integrity (min)	Insulation (min)
				Nominal (mm)	Measured (mm)	Nominal (mm)	Measured (mm)	Measured (mm)				
P112838-1003 Issue 3	6	H65S	PE100	25	26	2.0	3.0	N/A	None	Grout backfill	240	179
P112838-1004 Issue 1	1	H150S	PE100	160	160	14.6	15.4	N/A	None	None	240	182
P112838-1004 Issue 1	2	H65S	PVC	65	63	4.7	5.1	N/A	None	None	240	240
P112838-1004 Issue 1	3	H65S	PVC	65	63	4.7	5.0	5.0	Socket	None	240	240
P112838-1004 Issue 1	4	H65S	PE100	63	64	5.8	6.4	N/A	None	None	240	240
P112838-1004 Issue 1	5	H150S	PVC	100	110	3.2	3.8	N/A	None	Grout backfill	173	173
P112838-1004 Issue 1	6	H65S	PE-HD	63	63	3.0	3.3	N/A	None	None	240	240



Test report ref.	Specimen	Collar	Pipe type	Pipe external diameter		Pipe wall thickness		Socket/pipe bell end wall thickness		Socket/pipe bell end within the collar	Seal method	Integrity (min)	Insulation (min)
				Nominal (mm)	Measured (mm)	Nominal (mm)	Measured (mm)	Nominal (mm)	Measured (mm)				
P112838-1005 Issue 2	1	H150S	PP	110	110	-	3.4	-	3.4	Pipe bell end	PE foam strip + grout backfill	240	239
P112838-1005 Issue 2	2	H150S	PP	160	160	-	4.9	-	4.9	Pipe bell end	PE foam strip	8 ²	7 ²
P112838-1005 Issue 2	3	H110S	PVC	50	55	-	2.0	N/A	N/A	None	Grout backfill	240	240
P112838-1005 Issue 2	4	H150S	PE-HD	110	110	-	4.2	N/A	N/A	None	Grout backfill	240	202
P112838-1005 Issue 2	5	H150S	PE100	110	110	-	10.0	N/A	N/A	None	Grout backfill	240	193
P112838-1005 Issue 2	6	H150S	PE-HD	160	160	-	6.2	N/A	N/A	None	None	163	160
P112838-1006 Issue 1	1	H65S	PVC	40	40	3.0	3.3	N/A	N/A	None	Silicone	240	209



Test report ref.	Specimen	Collar	Pipe type	Pipe external diameter		Pipe wall thickness		Socket/pipe bell end wall thickness		Socket/pipe bell end within the collar	Seal method	Integrity (min)	Insulation (min)
				Nominal (mm)	Measured (mm)	Nominal (mm)	Measured (mm)	Nominal (mm)	Measured (mm)				
P112838-1006 Issue 1	2	H110S	None	N/A	N/A	N/A	N/A	N/A	N/A	N/A	N/A	143	143
P112838-1006 Issue 1	3	H110S	PE100	110	110	10.0	10.9	N/A	N/A	None	None	216	212
P112838-1006 Issue 1	4	H150S	PP	160	160	4.9	5.2	N/A	N/A	None	None	208	131
P112838-1006 Issue 1	5	H65S	PE-HD	32	32	3.0	3.5	N/A	N/A	None	Grout backfill	240	238
P112838-1006 Issue 1	6	H110S	PE100	50	50	4.6	5.4	N/A	N/A	None	Grout backfill	222	222
P112838-1007 Issue 1	1	H65S	PP	40	40	1.8	2.3	N/A	N/A	None	PE foam strip + grout backfill	240	240
P112838-1007 Issue 1	2	H110S	PP	110	109	2.7	3.3	N/A	N/A	None	PE foam strip	198	164



Test report ref.	Specimen	Collar	Pipe type	Pipe external diameter		Pipe wall thickness		Socket/pipe bell end wall thickness		Socket/pipe bell end within the collar	Seal method	Integrity (min)	Insulation (min)
				Nominal (mm)	Measured (mm)	Nominal (mm)	Measured (mm)	Nominal (mm)	Measured (mm)				
P112838-1007 Issue 1	3	H110S	PP	50	50	1.8	2.1	N/A	N/A	None	PE foam strip + grout backfill	226	226
P112838-1007 Issue 1	4	H150S	PP	160	160	3.9	4.6	N/A	N/A	None	PE foam strip	144	124
P112838-1007 Issue 1	5	H65S	PP	50	50	1.8	2.2	N/A	N/A	None	PE foam strip + silicone	240	214
P112838-1007 Issue 1	6	2 x H110S	2 x HDPE	2 x 110	2 x 110	2 x 4.0	4.6/4.5	N/A	N/A	None	None	223	175
P112838-1008 Issue 1	1	H110S	PVC	110	110	6.6	7.2	N/A	N/A	None	None	198	197
P112838-1008 Issue 1	2	H110S	PP	50	51	1.8	2.2	1.8	2.2	Pipe bell end	PE foam strip + grout backfill	240	239



Test report ref.	Specimen	Collar	Pipe type	Pipe external diameter		Pipe wall thickness		Socket/pipe bell end wall thickness		Socket/pipe bell end within the collar	Seal method	Integrity (min)	Insulation (min)
				Nominal (mm)	Measured (mm)	Nominal (mm)	Measured (mm)	Nominal (mm)	Measured (mm)				
P112838-1008 Issue 1	3	H150S	PVC	160	160	9.5	10.3	N/A	N/A	None	None	229	187
P112838-1008 Issue 1	4	H110S	PP	110	110	3.4	3.8	N/A	N/A	None	PE foam strip	240	175
P112838-1008 Issue 1	5	H150S	PVC	160	160	6.2	6.4	10.0	10.8	Socket	None	206	140
P112838-1008 Issue 1	6	H110S	PP	110	110	2.7	3.2	2.7	3.2	Pipe bell end	PE foam strip	240	182

Notes:

1. P112838-1002 Issue 1 – Failure due to specimen 1 flaming intensely and falling over towards specimen 2 along with pooling of flaming molten plastic that could not be extinguished. This specimen has therefore been ignored for the purposes of the extended application.
2. P112838-1005 Issue 2 - The pipe deformed and slid down out of the support collar after 8 minutes of test and melted. This specimen has therefore been ignored for the purposes of the extended application.



4 Extended application

4.1 Principles applied for the extension of the field of application

This extended application procedure is based on the available test results in accordance with EN 15882-3:2009.

4.2 Procedure

4.2.1 Principles common to all generic seal types

4.2.1.1 Separating elements – concrete or masonry

Variation	Rules
Decrease in thickness and/or density	Not permitted
Increase in thickness and/or density	Permitted except in the case of pipe closure devices where specific rules regarding the position of the seal within the separating element are outlined in the relevant section (see section 4.2.2.1)

The tested specimens were installed in 150mm-thick steel-reinforced concrete with an average measured density of 2240kg/m³.

4.2.1.2 Plastic pipes

Variation	Rules
Change in pipe dimensions	Permitted within the diameter and wall thickness range tested provided the seal thickness and depth remains the same across the pipe dimension range. In the case of pipe closure devices this refers to the thickness and length of the intumescent component.

For the purposes of this extended application report, test data for the H100S and H110S fire collars has been combined as the thickness and length of the intumescent component in both collars is the same.

The PE100 pipes detailed above in section 3 are PE-HD pipes that comply with EN 1519-1.

4.2.2 Principles to specific generic seal types

4.2.2.1 Position within separating elements

Variation	Rules
Change of position within thickness of separating element	Distance of cast in collars, wraps or sleeves from the exposed face shall not be increased.



The tested fire collars were cast-in installed flush with the exposed face of the supporting construction. They may not therefore be recessed.

5 Extended application results

5.1 Application range – product family

The extended application is valid for a range of Sure Snap fire collars as defined in section 2.

5.2 Fire performance parameters

The results of the extended application are as detailed in the following sections.



5.2.1 PVC pipes

Collar type	Nominal pipe diameter range* (mm)	Nominal pipe wall thickness range* (mm)	Measured pipe diameter range (mm)	Measured pipe wall thickness range (mm)	Classification against EN 13501-2:2016
H65S	40 to 65	3.0 to 4.7	40 to 63	3.3 to 5.1	EI 180, E 240
H100S and H110S	50 to 100	2.0 to 6.6	55 to 110	2.0 to 7.2	EI 180, E 180
H150S	100 to 160	2.0 to 9.5	110 to 160	3.3 to 10.3	EI 120, E 120

*Note: The nominal pipe diameter and wall thickness ranges are provided for information only. If the nominal pipe dimensions for a specific pipe fall within the limits detailed above but the measured dimensions do not, the pipe is not covered by the scope of this extended application report.

5.2.2 PVC pipes with pipe socket within fire collar

Collar type	Nominal pipe diameter range* (mm)	Nominal pipe wall thickness range* (mm)	Measured pipe diameter range (mm)	Measured pipe wall thickness range (mm)	Measured socket wall thickness range (mm)	Classification against EN 13501-2:2016
H65S	40 to 65	3.0 to 4.7	40 to 63	3.5 to 5.0	3.5 to 5.0	EI 180, E 240
H100S and H110S	50 to 110	2.0 to 6.6	50 to 110	2.0 to 7.3	2.0 to 7.0	EI 180, E 180
H150S	100 to 150	6.2 to 9.5	110 to 160	6.4 to 10.1	7.0 to 10.8	EI 120, E 180

*Note: The nominal pipe diameter and wall thickness ranges are provided for information only. If the nominal pipe dimensions for a specific pipe fall within the limits detailed above but the measured dimensions do not, the pipe is not covered by the scope of this extended application report.



5.2.3 PP pipes

Collar type	Nominal pipe diameter range* (mm)	Nominal pipe wall thickness range* (mm)	Measured pipe diameter range (mm)	Measured pipe wall thickness range (mm)	Classification against EN 13501-2:2016
H65S	40 to 50	1.8	40 to 50	2.2 to 2.3	EI 180, E 240
H110S	50 to 110	1.8 to 3.4	50 to 110	2.1 to 3.8	EI 120, E 180
H150S	160	3.9 to 4.9	160	4.6 to 5.2	EI 120, E 120

*Note: The nominal pipe diameter and wall thickness ranges are provided for information only. If the nominal pipe dimensions for a specific pipe fall within the limits detailed above but the measured dimensions do not, the pipe is not covered by the scope of this extended application report.

5.2.4 PP pipes with pipe bell end within fire collar

Collar type	Nominal pipe diameter range* (mm)	Nominal pipe wall thickness range* (mm)	Measured pipe diameter range (mm)	Measured pipe wall thickness range (mm)	Measured pipe bell end wall thickness range (mm)	Classification against EN 13501-2:2016
H65S	40 to 50	1.8	40 to 50	1.8 to 2.7	1.8 to 2.7	EI 180, E 240
H110S	50 to 110	1.8 to 3.4	50 to 110	2.2 to 3.8	2.2 to 3.8	EI 180, E 240
H150S	110	3.4	110	3.4	3.4	EI 180, E 240

*Note: The nominal pipe diameter and wall thickness ranges are provided for information only. If the nominal pipe dimensions for a specific pipe fall within the limits detailed above but the measured dimensions do not, the pipe is not covered by the scope of this extended application report.



5.2.5 PE-HD pipes

Collar type	Nominal pipe diameter range* (mm)	Nominal pipe wall thickness range* (mm)	Measured pipe diameter range (mm)	Measured pipe wall thickness range (mm)	Classification against EN 13501-2:2016
H65S	25 to 63	2.0 to 5.8	26 to 64	3.0 to 6.4	EI 120, E 240
H100S and H110S	50 to 110	3.0 to 10.0	50 to 110	3.4 to 10.9	EI 120, E 120
H150S	110 to 160	4.2 to 14.6	110 to 160	4.2 to 15.4	EI 120, E 120

*Note: The nominal pipe diameter and wall thickness ranges are provided for information only. If the nominal pipe dimensions for a specific pipe fall within the limits detailed above but the measured dimensions do not, the pipe is not covered by the scope of this extended application report.

5.2.6 PE-X pipes

Collar type	Nominal pipe diameter range* (mm)	Nominal pipe wall thickness range* (mm)	Measured pipe diameter range (mm)	Measured pipe wall thickness range (mm)	Classification against EN 13501-2:2016
H65S	15 to 63	2.6 to 8.6	16 to 63	3.1 to 9.7	EI 90, E 90

*Note: The nominal pipe diameter and wall thickness ranges are provided for information only. If the nominal pipe dimensions for a specific pipe fall within the limits detailed above but the measured dimensions do not, the pipe is not covered by the scope of this extended application report.



6 Figures

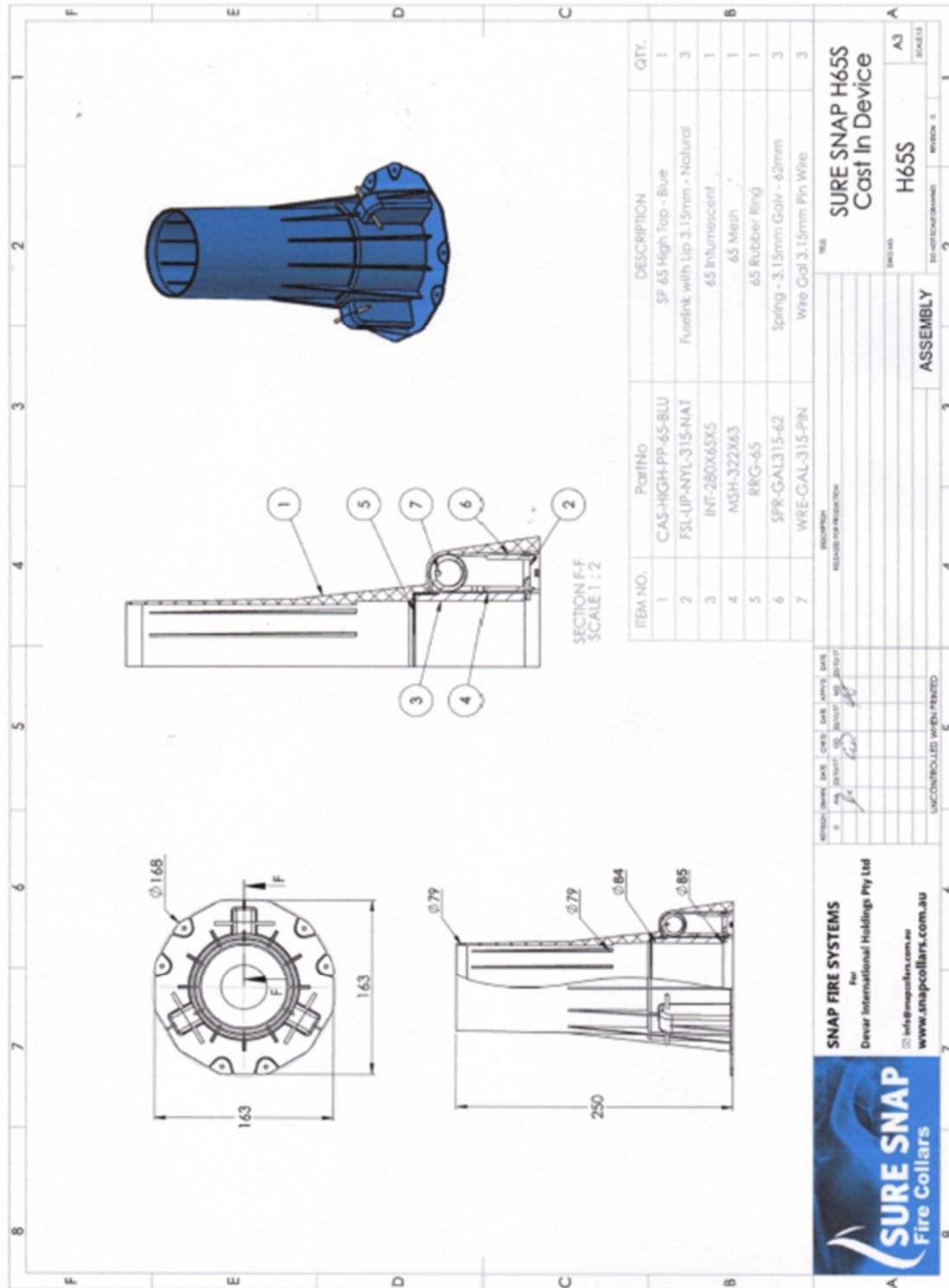

Figure 1 H65S fire collar

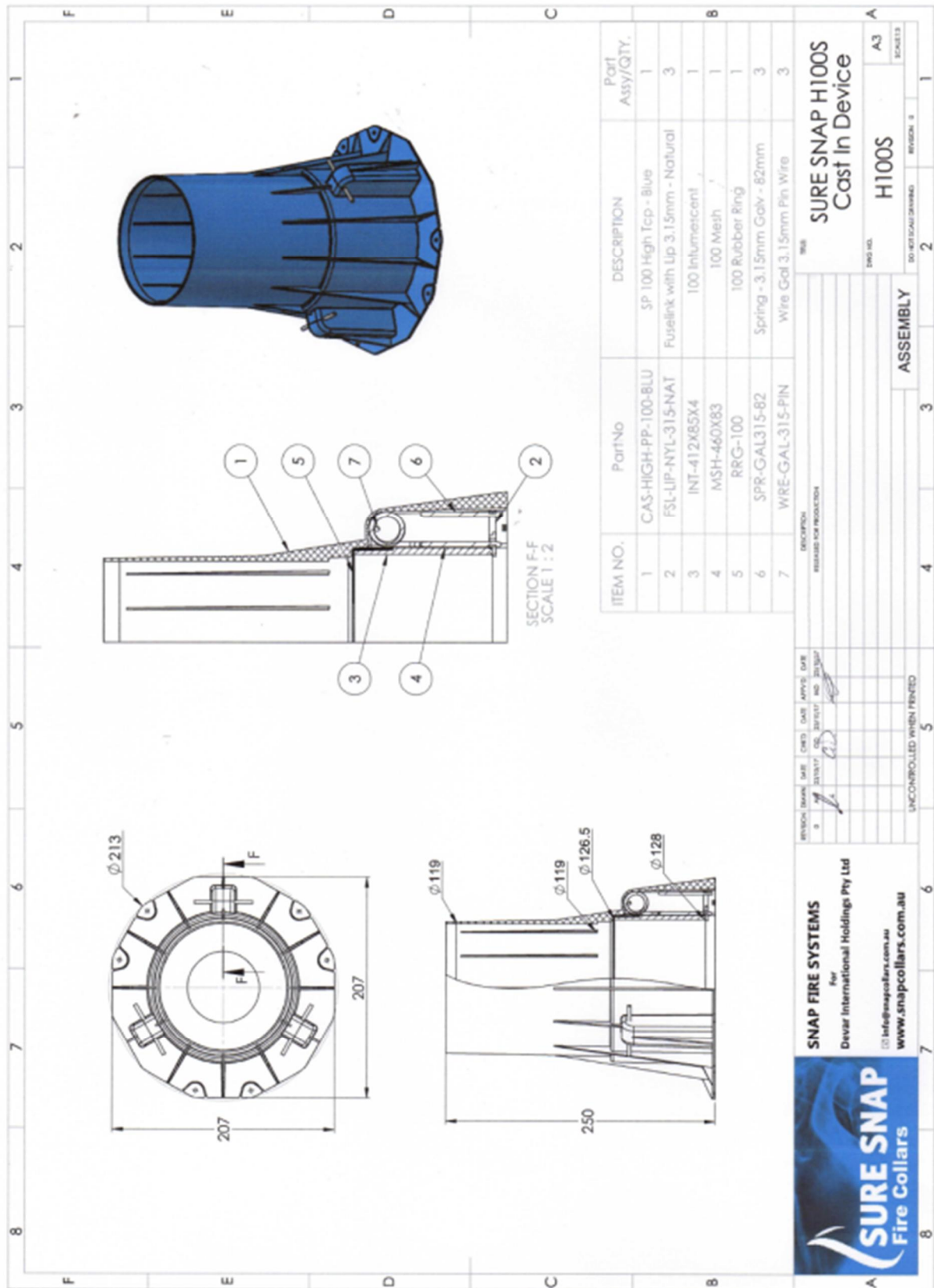

Figure 2 H100S fire collar

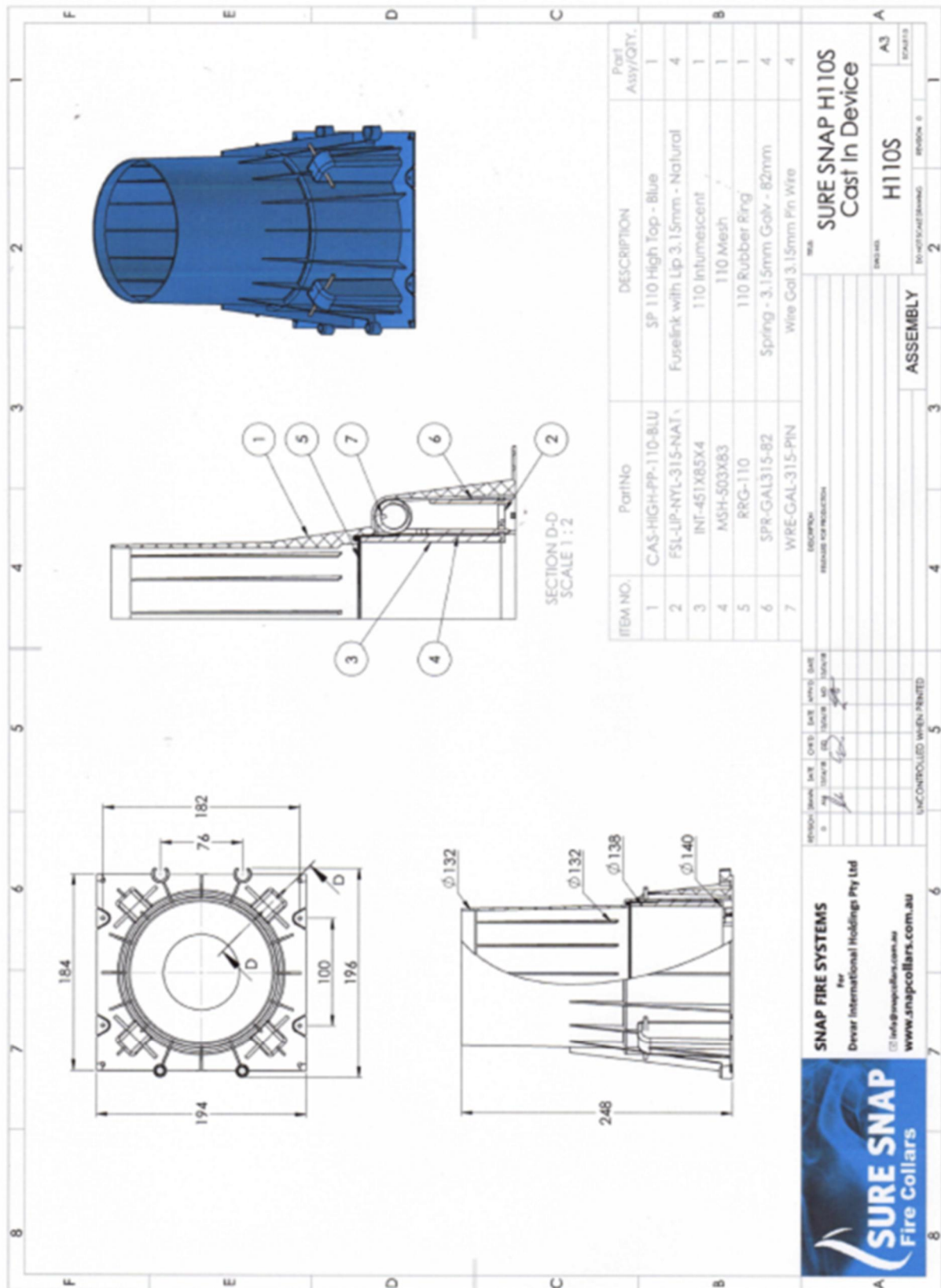

Figure 3 H110S fire collar

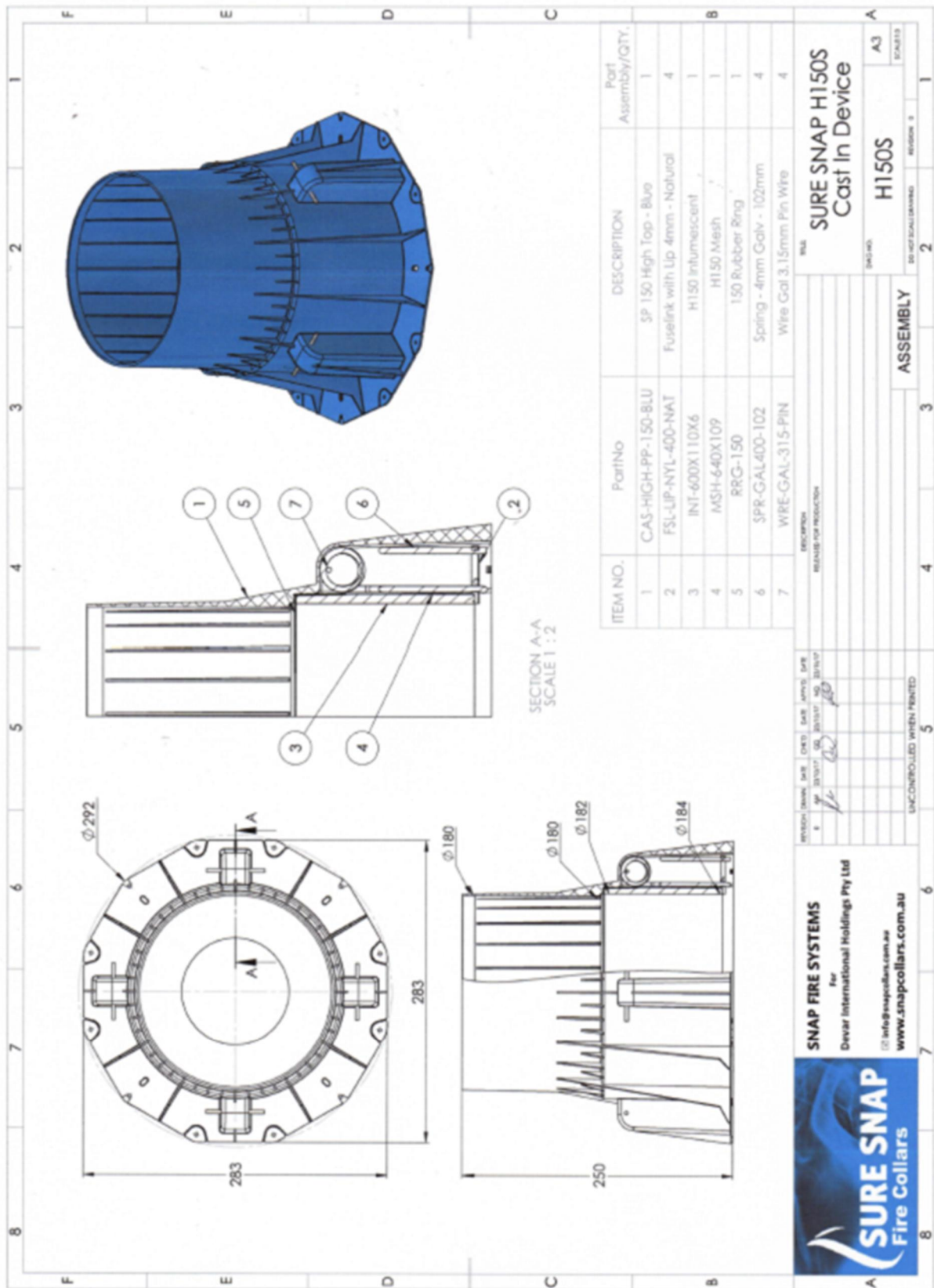

Figure 4 H150S fire collar



7 Additional statement

The extended application results relate to the behaviour of the Sure Snap fire collars under the particular conditions of the test; they are not intended to be the sole criterion for assessing the potential fire hazard of the collars in use.

8 Validity of the extended application

This assessment is issued on the basis of test data and information to hand at the time of issue. If contradictory evidence becomes available to BRE Global the extended application will be unconditionally withdrawn and the applicant will be notified in writing.

Similarly the extended application is invalidated if the assessed construction is subsequently tested since actual test data is deemed to take precedence over an expressed opinion. The extended application is valid for a period of five years after which it is recommended that it be submitted to BRE Global for re-evaluation.

Next review date: 06 June 2024